



Worldwide Applications **RAILWAY** **RE-RAILING SYSTEMS**



- Customer:RENFE (Spanish Railway)
- Country: SPAIN.
- Application: 700 bar Rerailing System.
- Products Supplied: Aluminium 700 Bar telescopic cylinders, Petrol Pump and Control Panel





Worldwide Applications
RAILWAY
INDUSTRIAL MAINTENANCE



Special press to test accurately the strength of the springs of a train suspension





Worldwide Applications

**RAILWAY
INDUSTRIAL MAINTENANCE**

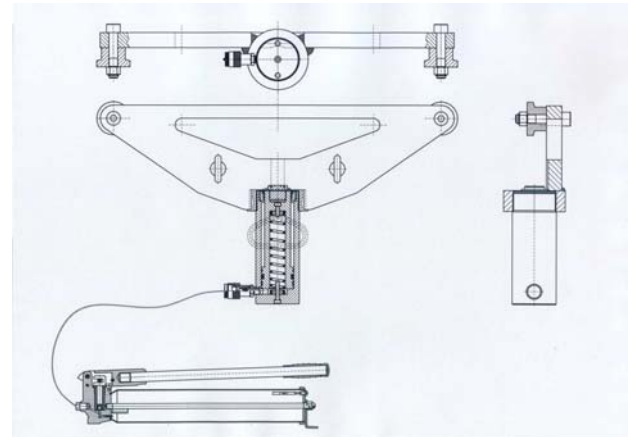

- Customer: RENFE.
- Country: Spain.
- Application: Special Railway Bender.
- Design based on a standard SM.030.15 cylinder and W.014.07 hand pump.
- Cylinder capacity 30 Tn.
- Special drawing 3503.